

Model 1630

Mobile hoist 1630

A budget friendly solution for home care



- Compact and reliable
- An integrated spreaderbar for convenience and use with Handi-slings
- Emergency down feature
- Ergonomic handle bar provides smooth steering making it easy to maneuver
- Width adjustable base for easy positioning. Low profile chassis with easy-to-roll castors for clearance under low objects



Lift & Care systems for people with reduced mobility

www.handimove.com

Mobile hoist 1630

● Dimensions (inch / mm)

| | |
|----|--------------|
| A | 51.97 / 1320 |
| B | 26.97 / 685 |
| B' | 19.49 / 495 |
| B1 | 42.91 / 1090 |
| C | 16.73 / 425 |
| C1 | 10.04 / 255 |
| C2 | 24.02 / 610 |
| D | 4.33 / 110 |
| H | 21.26 / 540 |
| H' | 48.82 / 1240 |
| H1 | 44.49 / 1130 |
| H2 | 70.08 / 1780 |
| H3 | 79.53 / 2020 |
| L | 45.28 / 1150 |
| L' | 11.02 / 280 |
| L1 | 45.28 / 1150 |
| L2 | 52.17 / 1325 |
| T | 22.83 / 580 |
| T' | 5.71 / 145 |

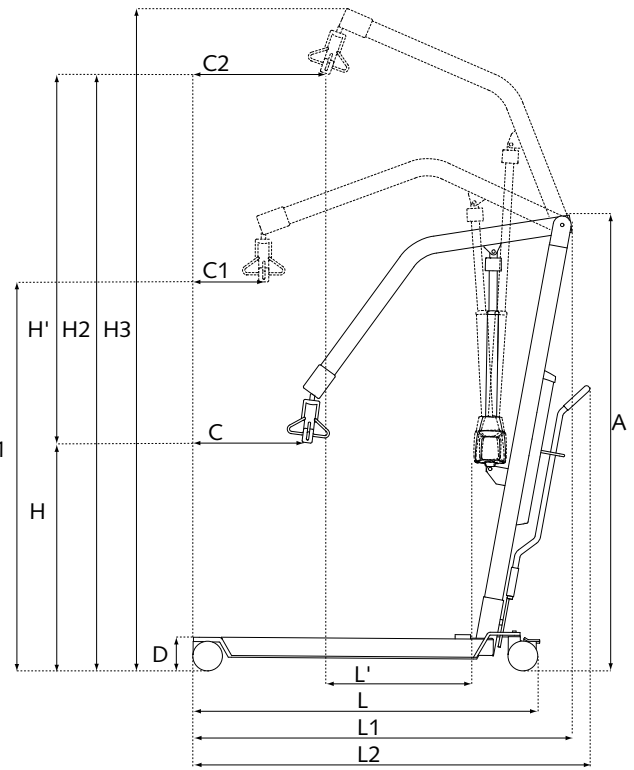
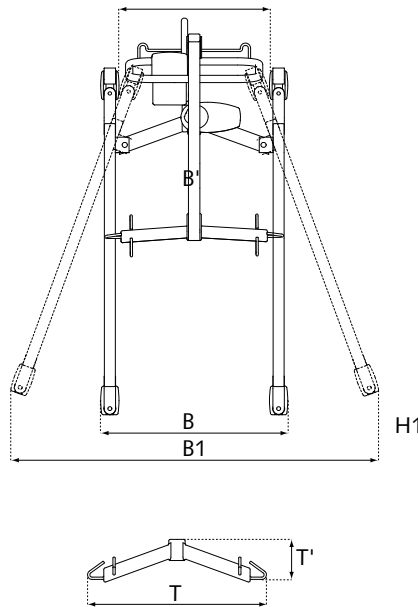

● Specifications

| | |
|--|--|
| Max. lifting capacity | 386 Lbs / 175 kg |
| Emergency down | mechanical |
| Weight | 90 Lbs / 41 kg |
| Batteries | sealed and maintenance-free 2 x 12 Vdc; 6,5 - 7,2 Ah |
| Number of lifts with fully charged batteries | 120 at 198.42 Lbs / 90 kg / 19.69 inch / 50.00 cm |
| Charger | input: 0.9 A 100 - 240 Vac 50 -60 Hz, class II output: 24 Vdc Max 1.3 A |
| Turning radius | 51.18 inch / 1300 mm |

● Speeds (inch/cm per sec.)

| | |
|----------------------------------|-------------|
| Raising (unloaded) | 1.42 / 3.60 |
| Lowering (unloaded) | 1.42 / 3.60 |
| Raising (load 198 Lbs / 90 kg) | 1.14 / 2.90 |
| Lowering (load 198 Lbs / 90 kg) | 1.3 / 3.30 |
| Raising (max. load) | 0.91 / 2.30 |
| Lowering (max. load) | 1.18 / 3.00 |

For free demonstration or further information

