

Model 1640

# Mobile hoist 1640

A versatile solution



- Accommodates both Handi-slings and Body Support
- Emergency down feature
- Ergonomic handle bar provides smooth steering making it easy to maneuver
- Width adjustable base for easy positioning. Low profile chassis with easy-to-roll castors for clearance under low objects
- Extended vertical lifting range for lifting from the floor onto a high bed and for assisting with standing and ambulation where indicated

Lift & Care systems for people with reduced mobility

[www.handimove.com](http://www.handimove.com)

# Mobile hoist 1640

## ● Dimensions (inch / mm)

A	61.61 / 1565
B	27.76 / 705
B'	19.88 / 505
B1	50.2 / 1275
C	21.06 / 535
C1	12.6 / 320
C2	22.64 / 575
D	4.33 / 110
H	30.51 / 775
H'	51.57 / 1310
H1	58.27 / 1480
H2	82.08 / 2085
H3	87.80 / 2230
L	48.43 / 1230
L'	19.29 / 490
L1	55.51 / 1410
L2	58.07 / 1475

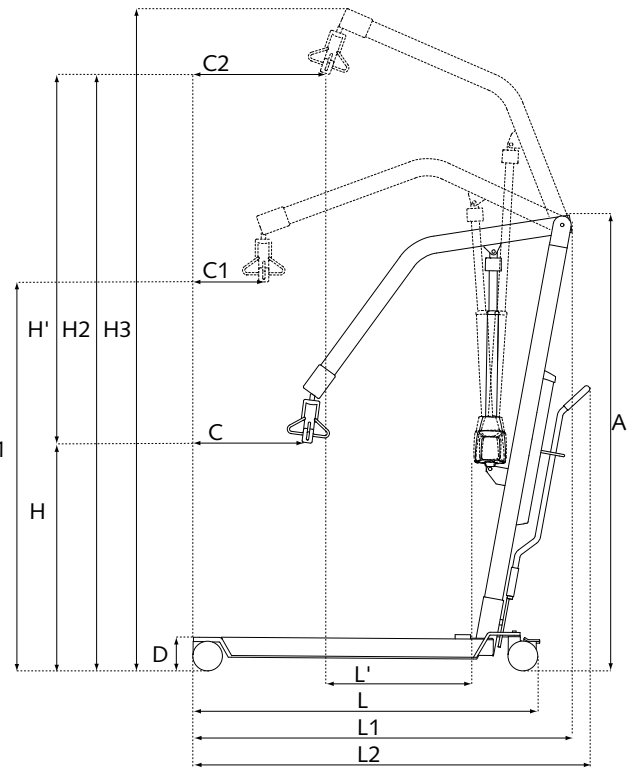
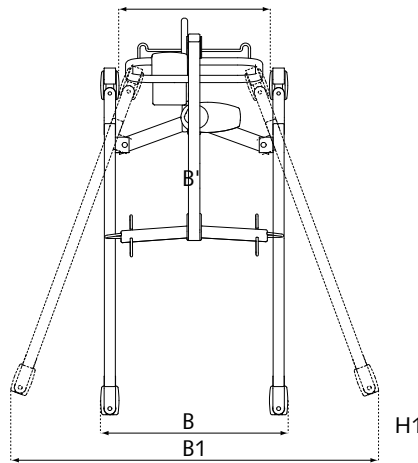

## ● Specifications

Max. lifting capacity	386 Lbs / 175 kg
Emergency down	mechanical
Weight	110.23 Lbs / 50 kg
Batteries	sealed and maintenance-free 2 x 12 Vdc; 6,5 - 7,2 Ah
Number of lifts with fully charged batteries	120 at 198.42 Lbs / 90 kg / 19.69 inch / 50 cm
Charger	input: 0.9 A 100 - 240 Vac 50 -60 Hz, class II output: 24 Vdc Max 1.3 A
Turning radius	53.94 inch / 1370 mm

## ● Speeds (inch/cm per sec.)

Raising (unloaded)	1.26 / 3.20
Lowering (unloaded)	1.26 / 3.20
Raising (load 198 Lbs / 90.00 kg )	1.1 / 2.80
Lowering (load 198 Lbs / 90.00 kg )	1.14 / 2.90
Raising (max. load)	0.91 / 2.30
Lowering (max. load )	1.06 / 2.70

For free demonstration or further information

