

Model 2540

# Portable motor

Versatility and portability

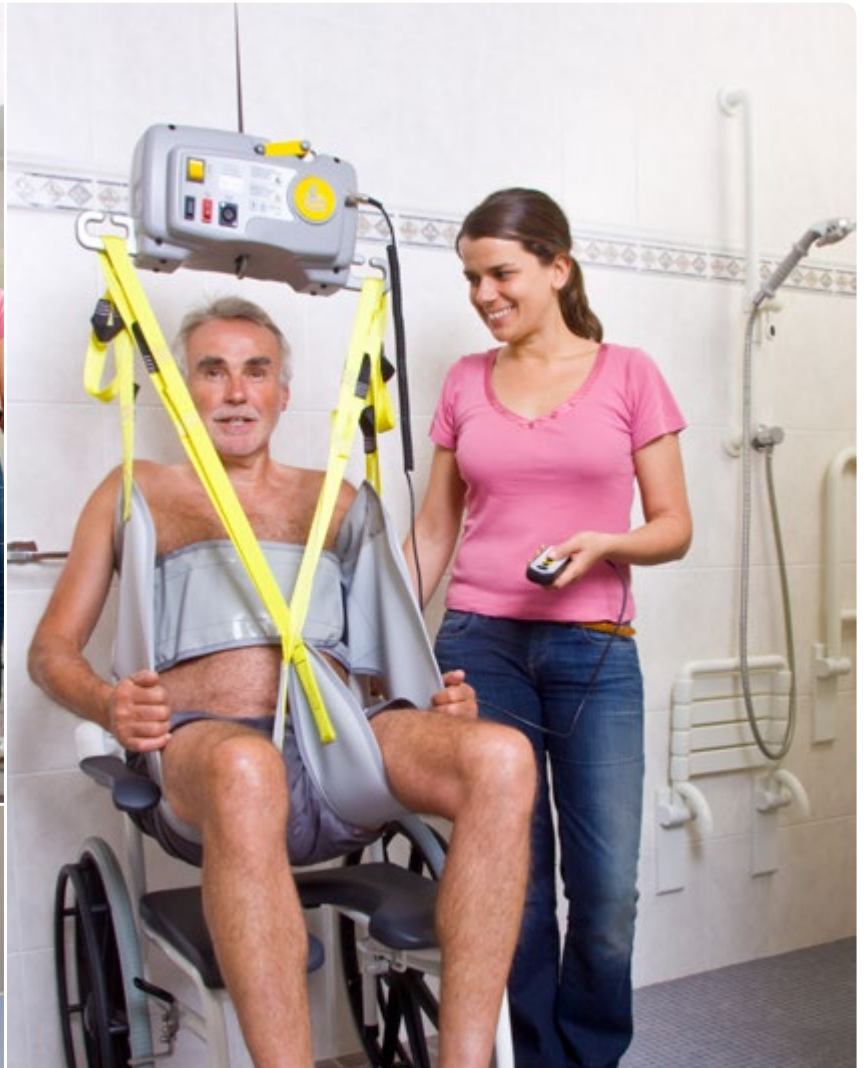

- Light & Compact
- Powerful, lifts up to 182 kg
- Durable, gets you through multiple lifts between charges
- Built-in spreader bar for Handi-Slings and built-in hook for SureHands Body Support
- Manual control and/or control panel
- Emergency down feature
- Easy to use
- Budget friendly

Lift & Care systems for people with reduced mobility

[www.handimove.com](http://www.handimove.com)

# Portable motor

## ● Portable motor with rail

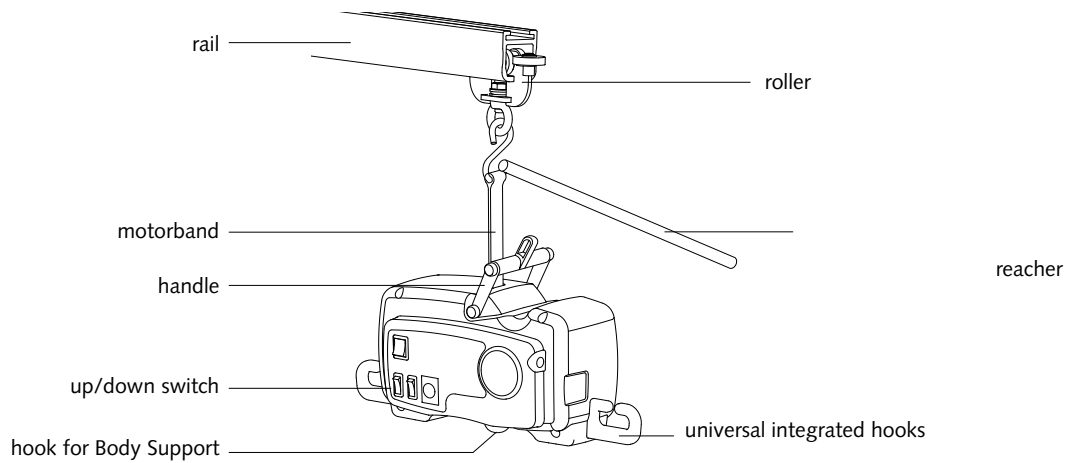

## ● Dimensions and specifications

Weight .....	8 kg
Max. Lifting Capacity .....	182 kg
Length.....	500 mm
Width .....	200 mm
Height .....	200 mm
Standard length of motorband.....	1700 mm
Length of motorband outside motor.....	1530 mm
Batteries .....	3 x 8 V
Capacity of batteries.....	3,2 Ah ea
Number of lifts with full batteries.....	65 x with 100 kg over a distance of 50 cm
Motor cover composition.....	ABS
Acceleration and deceleration .....	Electric
Overhead rail composition.....	Aluminium alloy, white laquered

## ● With handi-slings or body support

Thanks to the integrated hooks on both sides of the motor and the swivel hook placed centrally at the bottom, the motor can be used with all Handi-slings or with the Body Support.

For free demonstration or further information

