

Model 2600

Mobile hoist Victor

For intensive and super fast use



- Lifts twice as fast
- Designed for intensive use
- Electrically adjustable base
- Usable in combination with various spreader bars, slings and Body Support
- Lifts from floor to high surfaces
- Aluminium construction for easy care
- Exchangeable battery box or direct charging
- Optional digital scale

Lift & Care systems for people with reduced mobility

www.handimove.com

Mobile hoist Victor

● Dimensions (mm)

A	1725
B	660
B1	1150
H	775
H1	1530
H2	2240
h	120
C	440
C1	170
C2	620
L	1275
E	54

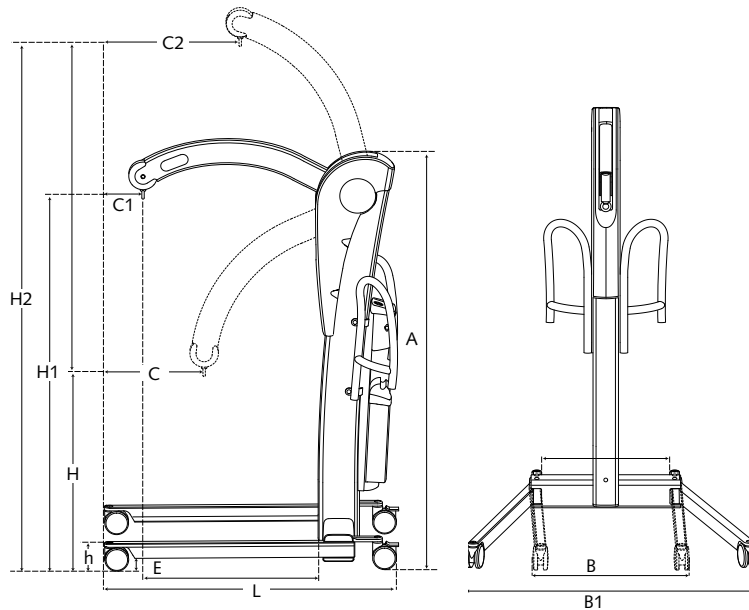

● Specifications

Mobile hoist

Construction.....aluminium; gloss finish
 Covers.....ABS
 Weight.....58 kg
 Motor/actuator.....24 Vdc, 13 A
electric/hydraulic
 Weight batterybox.....6,2 kg
 Safe working load.....225 kg
 Emergency switch.....present
 Wheels:.....front ø 100 mm
rear ø 100 mm with brakes
can be disassembled for maintenance
 Emergency down.....mechanical
 Noise.....66 dBA
 Battery-indicator.....acoustic
 Batteries.....2x12 Vdc; 7.2 Ah

Charger- in:.....0.9 A 100 - 240 VAC
50 - 60 Hz, klasse II
 Charger- out:.....24 Vdc
Max 1.3 A
 Number of lifts when fully charged...160 lifts with 90 kg/distance 50 cm
 Safety class.....IPx0
 Charging time after signal.....4 hours
 Wall-mount charger.....optional
 Extra battery box.....optional

● Speeds

Speed up

without load.....5,2 cm/sec
 load 90 kg.....4,9 cm/sec
 load 225 kg.....4,6 cm/sec

Speed down

without load.....4,9 cm/sec
 load 90 kg.....5,7 cm/sec
 load 225 kg.....5,7 cm/sec

For free demonstration or further information

